

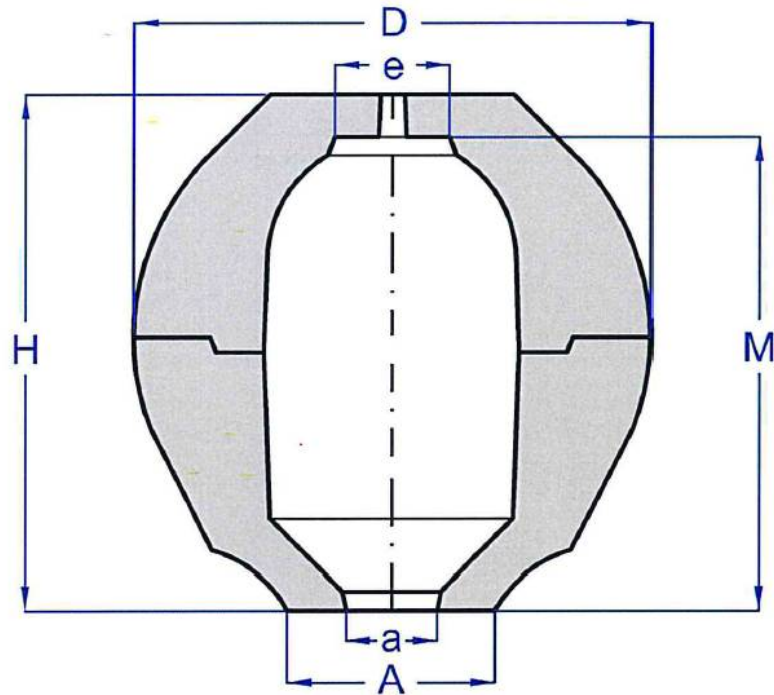

SLEEVES EXO 30



L

Type	Modulus (cm)	Capacity (cm ³)	D (mm)	H (mm)	A (mm)	a (mm)	M (mm)	e (mm)
L60	1,1	18	60	60	30	15	52	9
L70	1,3	28	70	80	34	16	73	9
L80	1,5	50	80	90	40	20	77	11
L90	1,7	73	90	100	44	21	92	13
L100	2	112	100	100	48	24	91	15
L120	2,3	186	120	120	54	24	109	17
L130	2,7	260	130	130	58	27	117	19
L140	3,3	332	140	140	72	30	127	20
L140L	3,5	410	140	155	72	30/40	147	20
L170	3,8	600	170	165	94	34/41	152	24

For orders, follow the next information:
L (type) / a (hole) : ex. L170 / 34

Board authorization

TOLERANCES

TYPE	H	A	a	M	e
L60 - L80	±2	±1,5	±1	±1,5	±1,5
L90 - L130	±2,5	±1,5	±1	±1,5	±1,5
L140 - L170	±3	±2	±1	±2	±2