

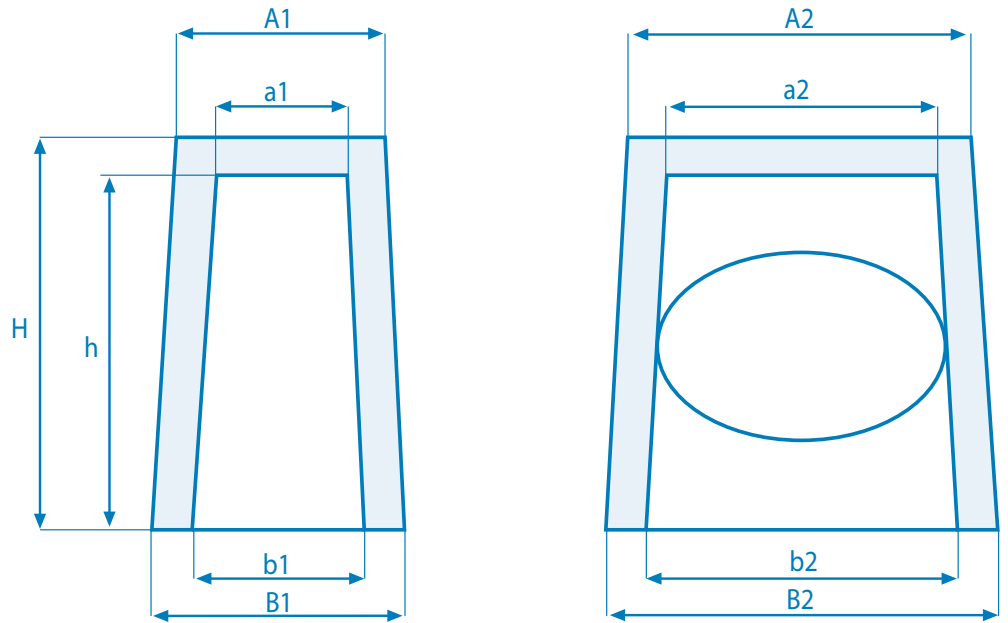

OVAL SLEEVES

TERMIK EXO 26



TYPE **OVP**

TYPE	a1 mm	a2 mm	A1 mm	A2 mm	b1 mm	b2 mm	B1 mm	B2 mm	h mm	H mm	Capacity dm ³	Modulus	
												Termik	Geom.
OVP 5/8	45	70	71	94	51	76	74	97	69	80	0,22	1,74	1,09
OVP 6/9	55	85	81	110	61	91	85	115	78	92	0,36	2,04	1,29
OVP 7/10	64	99	93	129	72	107	97	133	88	101	0,55	2,31	1,49
OVP 8/11	72	114	108	149	80	122	113	153	98	115	0,80	2,62	1,69

Date of issue
JULY 2015

Board authorization

TOLERANCES

a1	a2	A1	A2	b1	b2	B1	B2	h	H
± 1,5 mm	± 1,5 mm	± 1,5 mm	± 1,5 mm	± 1,5 mm	± 1,5 mm	± 1,5 mm	± 1,5 mm	± 2,5 mm	± 2,5 mm