

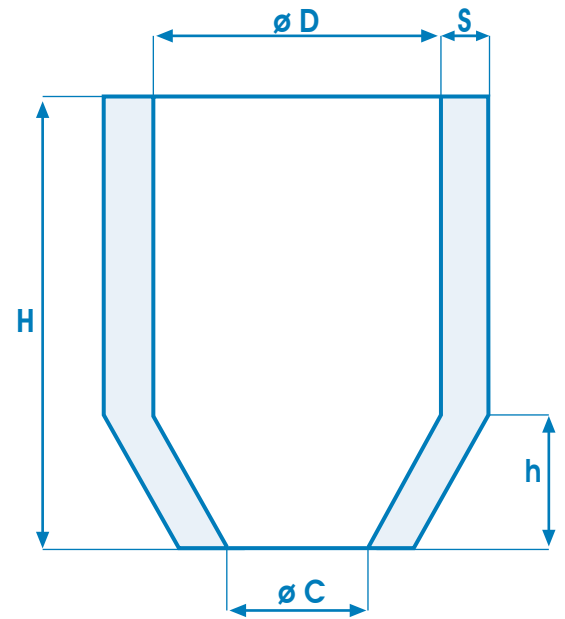

MANCHONS TRONCONIQUES TERMIK ISOL 53 - ISOL 30



TYPE **S**

TYPE	D mm.	C mm.	H mm.	h mm.	S mm.	Volume dm ³	Module Termik
S1	40	17	75	25	8	0,08	1,00
S2	60	45	90	30	8	0,24	1,60
S3	80	50	150	40	9	0,69	2,20
S4	100	55	150	40	10	1,06	2,70
S5	120	65	150	40	11	1,52	3,10
S6	140	80	200	40	13	2,85	3,80
S150	150	75	200	40	13	3,26	3,90
S7	160	90	200	40	14	3,72	4,00
S8	180	110	200	40	15	4,74	4,30
S9	200	120	200	60	16	5,74	4,50
S10	250	155	200	50	17	8,84	5,30
S11	300	185	200	80	18	12,15	5,70

Date d'emission
JUILLET 2015

Autorisation Direction

TOLÉRANCES

DIMENSION	DIAMÈTRE	ÉPAISSEUR	HAUTEUR
30-100	± 5 mm	-2 mm	-10 mm
110-200	± 5 mm	-2 mm	-10 mm
220-300	± 5 mm	-3 mm	-10 mm