

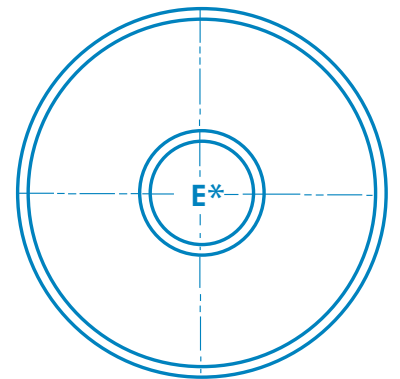

ANIMETTE DI ROTTURA IN SILICE

TIPO MTN

Tipo	D mm.	d mm.	H mm.	C mm.	V mm.	E cm ²
MTN16	40	36	8	15	3	1,8
MTN22	40	36	8	15	3	1,8
MTN29	54	38	12	15/20	3	1,8
MTN30	54	38	12	15/20	3	1,8
MTN32	40	36	8	15	3	1,8
MTN34	54	38	12	15/20	3	1,8
MTN39	54	38	12	15/20	3	1,8
MTN50	60	56	10	17	3	2,3
MTN75	60	56	10	17	3	2,3
MTN76	70	56	15	17	3	2,3
MTN82	60	56	10	17	3	2,3
MTN89	82	78	11	19	3	2,8
MTN115	66	62	11	18	3	2,5
MTN133	66	62	11	18	3	2,5
MTN153	82	78	11	19/40	4	2,8
MTN185	90	86	11	20/30	4	3,1
MTN232	90	86	11	20/30	4	3,1
MTN234	78	60	15	18	4	2,5
MTN261	90	94	11	21	4	3,5
MTN270	98	94	11	21	4	3,5
MTN333	98	94	11	21/30/45	4	3,5
MTN409	110	95	18	25/50	5	4,9
MTN474	128	15	18	41	5	13,2
MTN584	110	95	18	25/50	5	4,9
MTN674	110	95	18	25/50	5	4,9
MTN764	110	95	18	25/50	5	4,9
MTN774	128	115	18	28/50/58	5	6,2

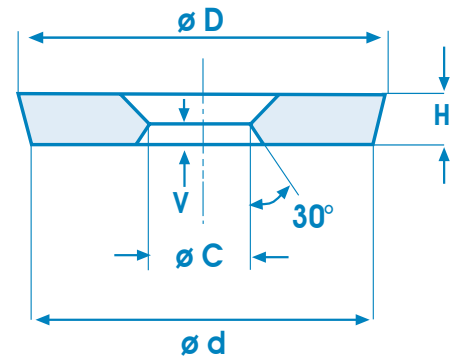
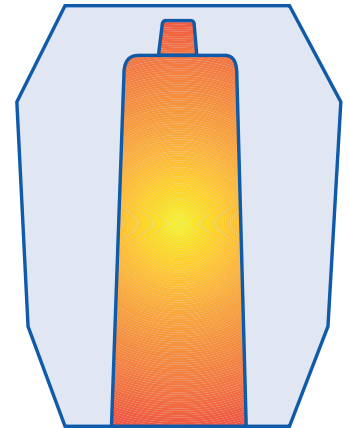

E* = Area di rottura

Data emissione:
LUGLIO 2015

Autorizzazione Direzione:

TOLLERANZE

D	d	H	C	V
± 2 mm	± 2 mm	± 3 mm	± 2 mm	± 2 mm