



VERENGTE OVALE SPEISERN ISO-EXO

TERMIK EXO 23 - EXO 25B - EXO 27

TYP

OX

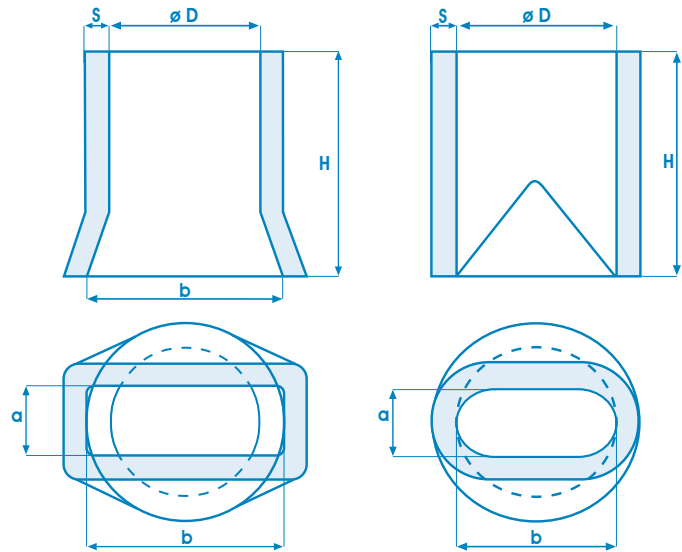

TYP	D mm	axb mm	H mm	S mm			Kapazität dm ³	Termik-Modul
				27	23	25B		
OX30*	30	20x35**	150	11	9		0,10	0,10
OX1*	40	25x45**	150	11	9		0,19	1,30
OX50*	50	50x55**	150	11	9		0,29	1,70
OX2*	60	35x70**	150	12	10		0,42	2,00
OX70*	70	40x80**	150	12	10		0,57	2,22
OX3*	80	45x95**	150	13	11		0,75	2,40
OX90*	90	50x105**	150	13	11		0,95	2,70
OX110*	110	55x130**	150	15	12		1,43	3,10
OX4	100	60x100	150	15	12		1,00	2,80
OX5	120	60x120	150	16	13		1,45	3,20
OX6	140	90x140	200	19	16		2,74	3,70
OX7	160	90x160	200	21	17		3,46	4,15
OX8	180	100x180	200	22	18		4,37	4,55
OX9	200	110x200	200	23	19		5,38	4,75
OX220	220	120x220	200	23	19		6,50	5,05
OX10	250	135x250	200	25	20		8,37	5,50
OX11	300	170x300	200	26	21		11,94	5,95
OX12	350	200x350	200	27	22		16,60	6,40

* MANUELLE FORMUNG

** MANUELLE OVALISIERUNGSTOLERANZ ± 10 MM

Ausgabedatum
JULI 2015

Genehmigung der
Geschäftsleitung

TOLERANZEN

GRÖSSE	DURCHMESSER	STÄRKE	HÖHE
30-100	± 5 mm	-2 mm	-10 mm
110-200	± 5 mm	-2 mm	-10 mm
220-300	± 5 mm	-3 mm	-10 mm
350-600	± 10 mm	-3 mm	-10 mm